

# Gearmotor with Clutch and Brake Specifications • Structure • Wiring

## Specifications of clutch and brake Standard Type

Table-16

Item	Motor Capacity	3-Phase 0.1kW	3-Phase 0.2kW	3-Phase 0.4kW	3-Phase 0.75kW
Motor Capacity Designation		T010·T010W	T020·T020W	T040·T040W	075·075W
Brake Type		Magnet close			
Static Friction Torque (N·m){ kgf·m }		1.96{ 0.20 }	1.96{ 0.20 }	3.92{ 0.40 }	7.35{ 0.75 }
Dynamic Friction Torque (N·m){ kgf·m }		1.57{ 0.16 }	1.57{ 0.16 }	3.14{ 0.32 }	5.88{ 0.60 }
Exciting Voltage DC (Average) Rectifier Attached (V)		90			
Power (at 75 Clutch/Brake) (W)		10/12	10/12	14/16	13/19
Current (at 75 Clutch/Brake) (A)		0.11/0.14	0.11/0.14	0.15/0.18	0.14/0.21
Armature Braking Time ta(s)		0.010	0.010	0.015	0.020
Torque Buildup Time (s)		0.020	0.020	0.050	0.070
Torque Extinction Time (s)		0.015	0.015	0.020	0.040
Allowable Continuous Works (per time) (J){ kgf·m }		15{ 1.5 }	15{ 1.5 }	27{ 2.7 }	49{ 4.9 }
Allowable Total Work Emax (J)		1.2 × 10 <sup>8</sup>	1.2 × 10 <sup>8</sup>	2.2 × 10 <sup>8</sup>	4.3 × 10 <sup>8</sup>
	{ kgf·m }	1.2 × 10 <sup>7</sup>	1.2 × 10 <sup>7</sup>	2.2 × 10 <sup>7</sup>	4.3 × 10 <sup>7</sup>
Allowable Braking Frequency (times/minute)		50			

Note) The allowable braking frequency is a guideline value and it differs according to the using condition.

## Specifications of clutch and brake Reinforced Type

Table-17

Item	Motor Capacity	3-Phase 0.2kW	3-Phase 0.4kW	3-Phase 0.75kW
Motor Capacity Designation		T020·T020W	T040·T040W	075·075W
Brake Type		Magnet close		
Static Friction Torque (N·m){ kgf·m }		1.96{ 0.20 }	3.92{ 0.40 }	7.35{ 0.75 }
Dynamic Friction Torque (N·m){ kgf·m }		1.57{ 0.16 }	3.14{ 0.32 }	5.88{ 0.60 }
Exciting Voltage DC (Average) Rectifier Attached (V)		90		
Power (at 75 Clutch/Brake) (W)		14/15	13/18	11/12
Current (at 75 Clutch/Brake) (A)		0.15/0.17	0.14/0.20	0.13/0.13
Armature Braking Time ta(s)		0.010	0.015	0.020
Torque Buildup Time (s)		0.020	0.050	0.070
Torque Extinction Time (s)		0.015	0.020	0.040
Allowable Continuous Works (per time) (J){ kgf·m }		15{ 1.5 }	27{ 2.7 }	49{ 4.9 }
		2.2 × 10 <sup>8</sup>	4.3 × 10 <sup>8</sup>	5.5 × 10 <sup>8</sup>
Allowable Total Work Emax (J)		2.2 × 10 <sup>8</sup>	4.3 × 10 <sup>8</sup>	5.5 × 10 <sup>8</sup>
	{ kgf·m }	2.2 × 10 <sup>7</sup>	4.3 × 10 <sup>7</sup>	5.5 × 10 <sup>7</sup>
Allowable Braking Frequency (times/minute)		50		

- Note 1) The allowable braking frequency is a guideline value to avoid excessive motor temperature rise. Braking frequency can be increased when load is light or motor is sufficiently cooled. (Be sure to maintain the motor surface temperature below 80 °C.)
- 2) Be sure to avoid continuous energizing to the clutch/brake coil during the motor stops.
- 3) Use the rectifier attached for the power supply to the clutch/brake. If different type of rectifier is to be used, consult us.
- 4) The values of the static and dynamic friction torques are just guidelines and not guaranteed ones.

Note) The allowable braking frequency is a guideline value and it differs according to the using condition.

## Structure

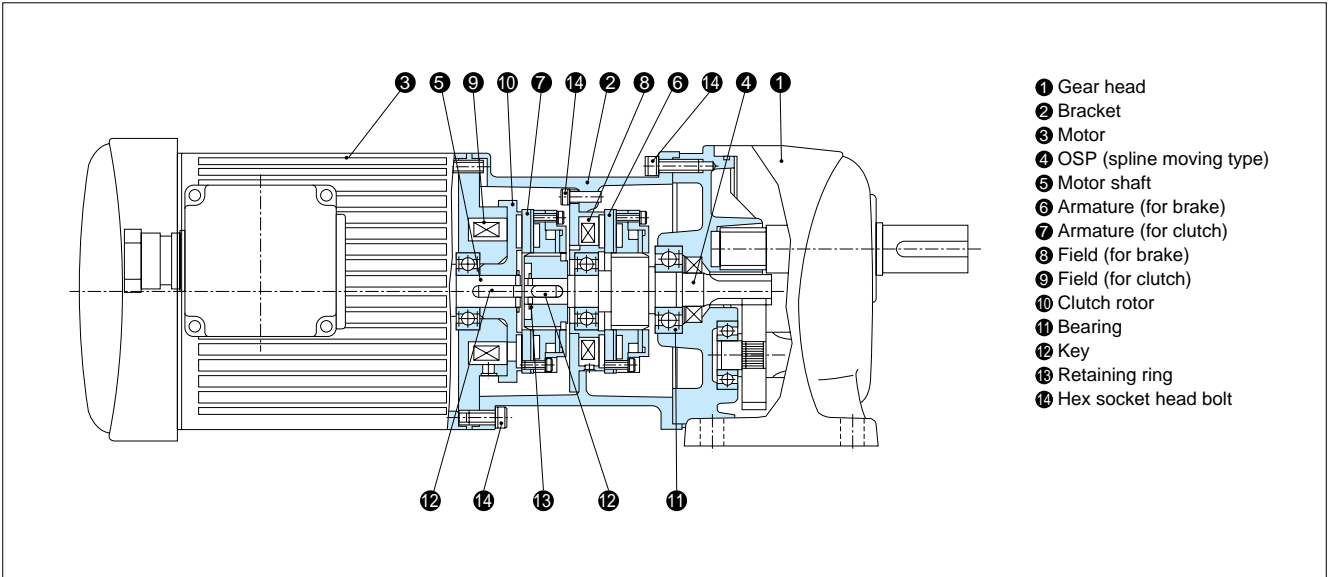

## Wiring Method

For the brake operation of this clutch/brake motor, DC voltage 90V should be employed. Connect the attached rectifier A200-D90 and the surge suppressor (ENC471D-10A) for quenching spark, according to the wiring method described below. For the dimension of the rectifier, refer to page E22.

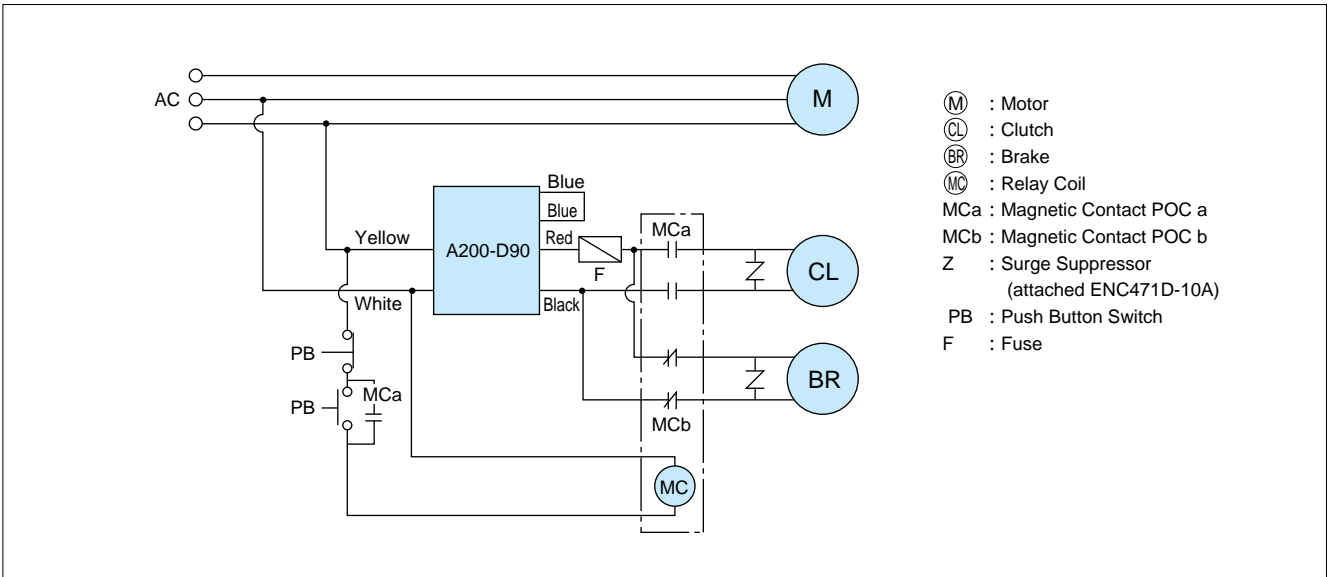

- Note 1)** For protecting the rectifier, put a fuse (capacity 1A) in the input or output side.
- As the rectifier contains diodes, improper wiring may cause fatal short-circuiting. So special care should be given to the wiring.
  - For the relay capacity for the clutch/brake circuit, DC110V, DC13 class is recommended for its ability of cutting off the inductive load (DC coil). In case of using non-contact relay, apply the rated voltage of AC240V equivalent (half-wave rectification switchable)
  - As for the wiring for 3-phase double voltage or a special voltage of over 230V model, be sure to connect 200V terminal (red lead wire, 0.75 kW for B terminal) which are extended out from the motor, to the input terminal of the rectifier.

Parallel Shaft (Performance Table/Dimension)

Gearmotor with Brake

Water-resistant, Outdoor Gearmotor with Brake

Gearmotor with Clutch/Brake

Reducer (Double Shaft)

S-Type Reducer

Right Angle Shaft (Performance Table/Dimension)

Gearmotor with Brake

Water-resistant, Outdoor Gearmotor with Brake

Gearmotor with Clutch/Brake

Reduce (Double Shaft)

S-Type Reducer

Hollow Shaft Solid Shaft Performance Table/Dimension

Gearmotor with Brake

Water-Resistant, Outdoor Gearmotor with Brake

Reduce (Double Shaft)

S-Type Reducer

Concentric Hollow Shaft Concentric Solid Shaft Performance Table/Dimension

Gearmotor with Brake

Water-Resistant, Outdoor Gearmotor with Brake

Reducer (Parallel Shaft)

S-Type Reducer

Technical Information

Standard Motors

Cautions for Safety

Option

GT-STEP Index Gearmotor

KOMPASS Gearbox