

Gearmotor with Brake Specifications • Structure

Brake Specifications

Table-13-1

Items	3-Phase								
	50W		0.1kW	0.2kW	0.4kW	0.75kW	1.5kW	2.2kW	
Motor Capacity Designation	T50·T50W ratio 1/240 and below		T50·T50W ratio 1/300 and above	T010 T010W	T020 T020W	T040 T040W	075 075W	150 150W	220 220W
Brake Type	"Power-off, Brake-on" Type (Spring Close)								
Static Friction Torque T_s (N·m) { kgf·m }	0.2{ 0.027 }	0.4{ 0.047 }	0.9{ 0.10 }	1.9{ 0.20 }	3.9{ 0.40 }	7.3{ 0.75 }	14.7{ 1.50 }	21.6{ 2.20 }	
Dynamic Friction Torque T_d (N·m) { kgf·m }	0.2{ 0.022 }	0.3{ 0.038 }	0.7{ 0.08 }	1.5{ 0.16 }	3.1{ 0.32 }	5.8{ 0.60 }	11.8{ 1.20 }	17.2{ 1.76 }	
Voltage DC (Average) Rectifier Attached (V)	90								
Power (at 75) (W)	4.5	12	14	14	16	24	46	46	
Current (at 75) (A)	0.05	0.13	0.15	0.15	0.18	0.27	0.51	0.51	
Allowable Total Work E_{max} (J)	1.5 × 10 ⁷	3.0 × 10 ⁷	1.5 × 10 ⁸	1.5 × 10 ⁸	1.5 × 10 ⁸	4.0 × 10 ⁸	6.0 × 10 ⁸	6.0 × 10 ⁸	
	{ kgf·m }	1.5 × 10 ⁶	3.0 × 10 ⁶	1.5 × 10 ⁷	1.5 × 10 ⁷	1.5 × 10 ⁷	4.0 × 10 ⁷	6.0 × 10 ⁷	
Allowable Braking Frequency (times/minute)	10								

Table-13-2

Items	1-Phase		
	100W	200W	400W
Motor Capacity Designation	S100 ·100	200	400
	S100W·100W	200W	400W
Brake Type	"Power-off, Brake-on" Type (Spring Close)		
Static Friction Torque T_s (N·m) { kgf·m }	0.9{ 0.10 }	1.9{ 0.20 }	3.9{ 0.40 }
Dynamic Friction Torque T_d (N·m) { kgf·m }	0.7{ 0.08 }	1.5{ 0.16 }	3.1{ 0.32 }
Voltage DC (Average) Rectifier Attached	90	90	
Power (at 75) (W)	14	14	24
Current (at 75) (A)	0.15	0.15	0.27
Allowable Total Work E_{max} (J)	1.5 × 10 ⁸	1.5 × 10 ⁸	4.0 × 10 ⁸
	{ kgf·m }	1.5 × 10 ⁷	1.5 × 10 ⁷
Allowable Braking Frequency (times/minute)	6		

- Note 1)** Allowable braking frequencies are guideline values to avoid excessive motor temperature rise. The braking frequency can be increased when loads are light or motor is sufficiently cooled. (Be sure to maintain the motor surface temperature below 80 °C)
- 2)** Avoid continuous energizing to the brake coil while the motor stops.
- 3)** Use the attached rectifier for the brake power supply. if other type of rectifier is to be used for power supply, consult us.
- 4)** The life of the contacting point of the 1-phase motor centrifugal switch is 300,000 times as a guideline.
- 5)** Static friction torque/Dynamic friction torque are guideline values and not guaranteed ones.

Brake Structure

Motor Capacity Designation

3-Phase/T50·T50W Reduction Ratio Below 1/240 Figure-1

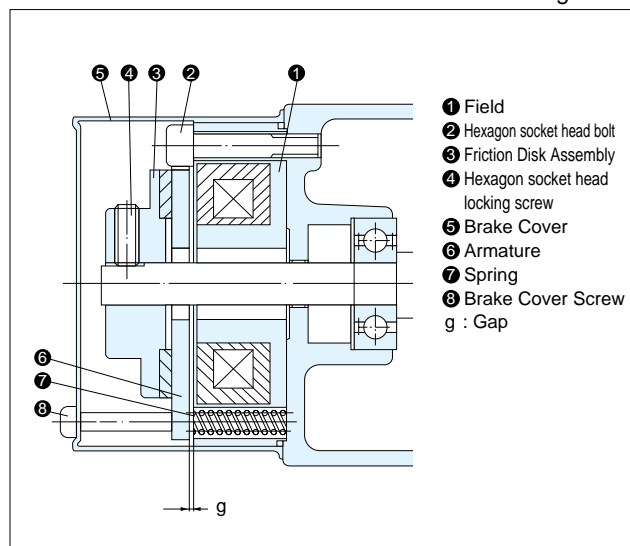

Motor Capacity Designation

3-Phase/T50·T50W Reduction Ratio Below 1/300 Figure-2

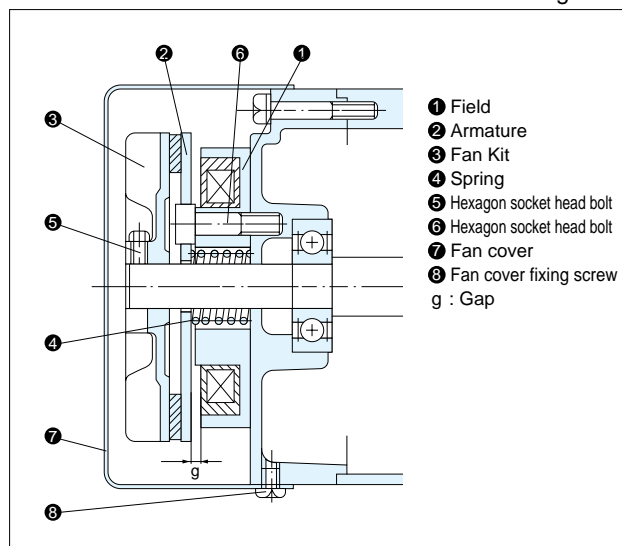

Brake Structure

Motor Capacity Designation

3-Phase / T010·T020·T040·075·T010W·T020W·T040W·075W

1-Phase / S100·100·200·400·S100W·100W·200W·400W

Figure-3

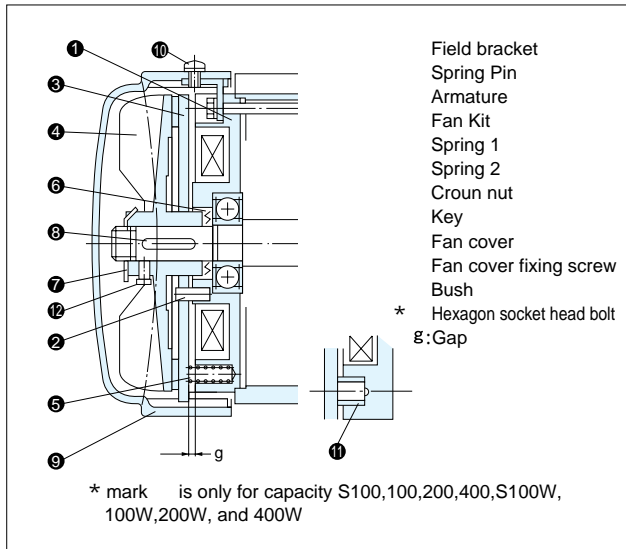

Motor Capacity Designation

3-Phase / 150·220·150W·220W

Figure-4

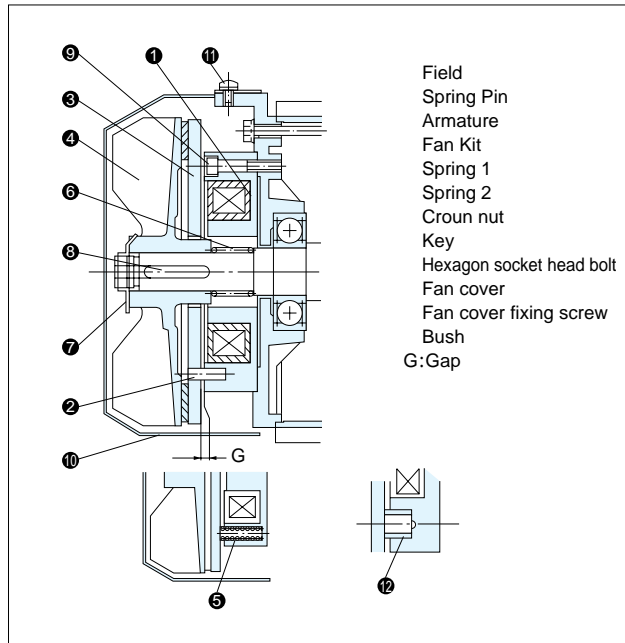

Brake Gap

As a result of using brake for an extended period of time, naturally brake gap grew and finally brake releasing become impossible. To avoid this trouble, be sure to adjust brake gap periodically (Every one year or every 1 ~ 1.5 million cycles). Refer to Page E33 for the dimension necessary for the space when taking off the motor fan cover at brake gap adjustment.

Table-14

Figure No.	Motor Capacity Designation		Gap for Suction Limit	Proper Gap
	3-Phase	1-Phase		
Figure-1	T50·T50W ratio 1/240 and below		G:0.5 and below	G:0.2 ± 0.1
Figure-2	T50·T50W ratio 1/300 and above		g:0.8 and below	g:0.4 ± 0.1
Figure-3	T010·T020·T010W·T020W	S100·100·200·S100W·100W·200W	g:2.3 and below	g:1.9 ± 0.1
	T040·T040W		g:1.8 and below	g:1.4 ± 0.1
Figure-4	0.75·0.75W	400·400W	g:2.4 and below	g:2.0 ± 0.1
	150·220·150W·220W		G:1.0 and below	G:0.4 ± 0.1

Parallel Shaft
(Performance
Table/Dimension)

Gearmotor with
Brake

Water-resistant,
Outdoor
Gearmotor
with Brake

Gearmotor with
Clutch/Brake

Reducer
(Double Shaft)

S-Type
Reducer

Right Angle Shaft
(Performance
Table/Dimension)

Gearmotor with
Brake

Water-resistant,
Outdoor
Gearmotor
with Brake

Gearmotor with
Clutch
/Brake

Reduce
(Double Shaft)

S-Type
Reducer

Hollow Shaft
Solid Shaft
Performance
Table/Dimension

Gearmotor with
Brake

Water-resistant,
Outdoor
Gearmotor
with Brake

Reduce
(Double Shaft)

S-Type
Reducer

Concentric Hollow Shaft
Concentric Solid Shaft
Performance Table/
Dimension

Gearmotor with
Brake

Water-resistant,
Outdoor
Gearmotor
with Brake

Reducer
(Parallel Shaft)

S-Type
Reducer

Technical
Information

Standard
Motors

Cautions
for Safety

Option

GT-STEP
Index
Gearmotor

KOMPASS
Gearbox

Water-Resistant Specifications

Gearmotor with Brake Specifications • Structure

Brake Specifications

Items	3-Phase			
	0.1kW	0.2kW	0.4kW	0.75kW
Motor Capacity Designation	T010 T010W	T020 T020W	T040 T040W	075 075W
Brake Type	"Power-off, Brake-on" Type (Spring Close)			
Static Friction Torque T_s (N·m) { kgf·m }	0.98 { 0.10 }	1.96 { 0.20 }	3.92 { 0.40 }	7.35 { 0.75 }
Dynamic Friction Torque T_d (N·m) { kgf·m }	0.78 { 0.08 }	1.57 { 0.16 }	3.14 { 0.32 }	5.88 { 0.60 }
Voltage DC (Average) Rectifier Attached (V)	90			
Power (at 75) (W)	10	16	18	22
Current (at 75) (A)	0.11	0.18	0.20	0.25
Allowable Total Work E_{max} (J)	1.5×10^8	1.5×10^8	1.5×10^8	4.0×10^8
	{ kgf·m }	1.5×10^7	1.5×10^7	4.0×10^7
Allowable Braking Frequency (times/minute)	10			

Brake Structure

0.1kW Outer Disk Type

Figure-6

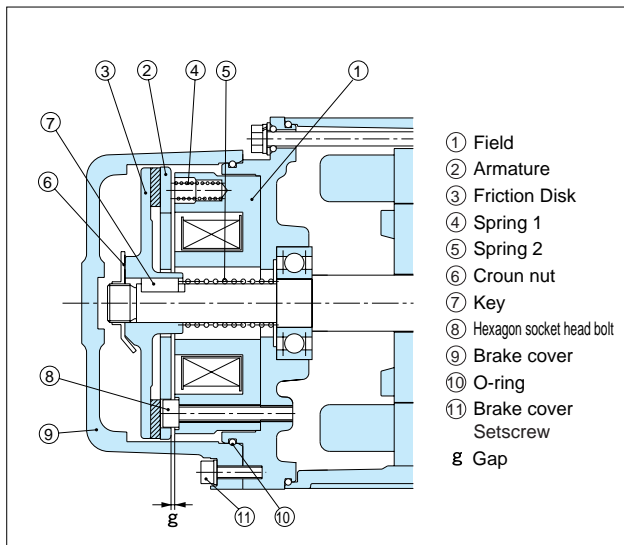

0.2kW ~ 0.75kW Fan Attached Type

Figure-7

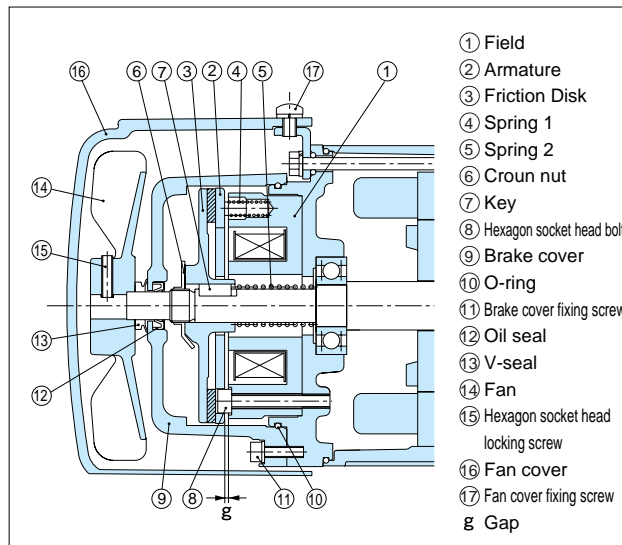

Brake Gap

As a result of using brake for an extended period of time, naturally brake gap grew and finally brake releasing become impossible. To avoid this trouble, be sure to adjust brake gap periodically (Every one year or every 1.5 million cycles). Refer to Page E33 for the necessary space when taking off the brake cover / motor fan cover at brake gap adjustment.



Gap adjustment should strictly be done according to the handling manual. Failure to observe this warning may cause unexpected trouble such as water getting through

Figure No.	Motor Capacity Designation	Gap for Suction	Limit Proper Gap
	3-Phase		
Fig.6	T010·T010W	g:0.8以下	g:0.3±0.1
Fig.7	T020·T040·T020W·T040W	g:0.7以下	g:0.3±0.1
Fig.7	075·075W	g:0.9以下	g:0.3±0.1

Parallel Shaft (Performance Table/Dimension)

Gearmotor with Brake

Water-resistant, Outdoor Gearmotor with Brake

Gearmotor with Clutch/Brake

Reducer (Double Shaft)

S-Type Reducer

Right Angle Shaft (Performance Table/Dimension)

Gearmotor with Brake

Water-resistant, Outdoor Gearmotor with Brake

Gearmotor with Clutch /Brake

Reduce (Double Shaft)

S-Type Reducer

Hollow Shaft Solid Shaft Performance Table/Dimension

Gearmotor with Brake

Water-Resistant, Outdoor Gearmotor with Brake

Reduce (Double Shaft)

S-Type Reducer

Concentric Hollow Shaft Concentric Solid Shaft Performance Table/Dimension

Gearmotor with Brake

Water-Resistant, Outdoor Gearmotor with Brake

Reducer (Parallel Shaft)

S-Type Reducer

Technical Information

Standard Motors

Cautions for Safety

Option

GT-STEP Index Gearmotor

KOMPASS Gearbox