

Overhung Load (O.H.L.)

An overhung load is a suspending load imposed on a shaft. In the coupling of reducer shaft and other machine, if chains, belts and gears are used, this O.H.L. must be taken into consideration.

$$O.H.L. = \frac{T_{LE} \times K_1 \times K_2}{R} \text{ (N } \times \text{ kgf)}$$

T_{LE} : Equivalent output torque imposed on reducer shaft (N·m } kgf·m }
 R : Pitch Circle Radius(m) of sprocket, pulley, gear, etc. attached to reducer shaft.
 K_1 : Factor for the connecting method (Refer to Table-4)
 K_2 : Factor for the load point (Refer to Table-5)

Be sure that the OHL value calculated by above formula should not exceed the allowable OHL value listed in the performance table.

Factor K₁

Table-4

Connecting Method	K ₁
Chain, Timing Belt	1.00
Gear	1.25
V-Belt	1.50

Factor K₂

Table-5

Load Point	K ₂
Root of the shaft	0.75
Center of the shaft	1.00
End of the shaft	1.50

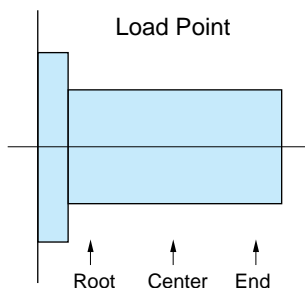

Thrust Load

The thrust load values of F and F2 Series hollow shaft type are listed in the performance table. If there is a possibility of having excessive thrust load in the operating condition, consult us.

- Parallel Shaft (Performance Table/Dimension)
- Gearmotor with Brake
- Water-resistant, Outdoor Gearmotor with Brake
- Gearmotor with Clutch/Brake
- Reducer (Double Shaft)
- S-Type Reducer
- Right Angle Shaft (Performance Table/Dimension)
- Gearmotor with Brake
- Water-resistant, Outdoor Gearmotor with Brake
- Gearmotor with Clutch /Brake
- Reduce (Double Shaft)
- S-Type Reducer
- Hollow Shaft Solid Shaft Performance Table/Dimension
- Gearmotor with Brake
- Water-resistant, Outdoor Gearmotor with Brake
- Reduce (Double Shaft)
- S-Type Reducer
- Concentric Hollow Shaft Concentric Solid Shaft Performance Table Dimension
- Gearmotor with Brake
- Water-Resistant, Outdoor Gearmotor with Brake
- Reducer (Parallel Shaft)
- S-Type Reducer
- Technical Information
- Standard Motors
- Cautions for Safety
- Option
- GT-STEP Index Gearmotor
- KOMPASS Gearbox

F Series Overhung Load on a Hollow Shaft(O.H.L.)

Flange Mounting

(1) Load Point of O.H.L.

Allowable OHL is calculated at the point 20mm off from the end of output shaft.

(2)-1 Adjustment of O.H.L. without any support by pillow

When load point of O.H.L. (L) become greater than 20mm, the allowable O.H.L. can be corrected by the following formula:

$$\text{Bearable O.H.L. (N } \times \text{ kgf)} = \frac{A + 20}{A + L} \times \text{Allowable O.H.L. (N } \times \text{ kgf)}$$

Note) Refer Table-6-1 for A.

Table-6-1

Frame Number	A (mm)
20	68.5
25	84.5
30	91
35	98
45	113
55	150

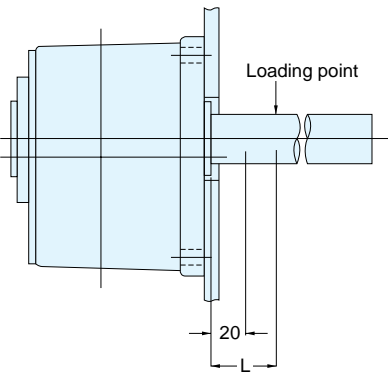

(2)-2 Correction of O.H.L. when supported by pillow at one end

$$\text{Bearable O.H.L. (N } \times \text{ kgf)} = \frac{S}{S - L} \times \text{Allowable O.H.L. (N } \times \text{ kgf)}$$

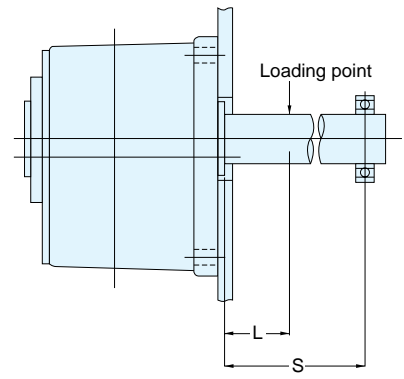

F3 Series Overhung Load on a Hollow Shaft(O.H.L.)

Flange Mounting

(1) Load Point of O.H.L.

Allowable OHL is calculated at the point 20mm off from the end of output shaft.

(2)-1 Adjustment of O.H.L. without any support by pillow

When load point of O.H.L. (L) become greater than 20mm, the allowable O.H.L. can be corrected by the following formula:

$$\frac{A + 20}{A + L}$$

Note) Refer Table-6-2 for A.

Table-6-2

Frame Number	A (mm)
20	68.5
25	84.5
30	91
35	98
45	113
50	139
55	184.5

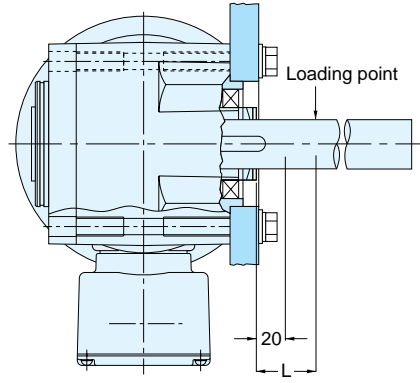

(2)-2 Correction of O.H.L. when supported by pillow at one end

$$\text{Bearable O.H.L. (N } \times \text{ kgf)} = \frac{S}{S - L} \times \text{Allowable O.H.L. (N } \times \text{ kgf)}$$

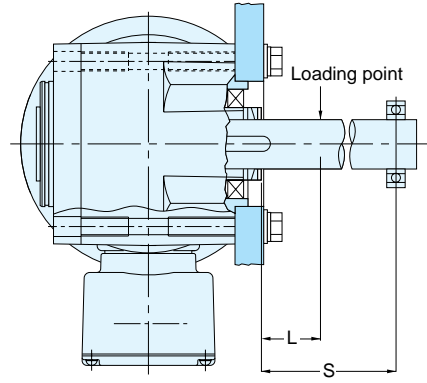

Parallel Shaft (Performance Table/Dimension)

- Gearmotor with Brake
- Water-resistant, Outdoor Gearmotor with Brake
- Gearmotor with Clutch/Brake
- Reducer (Double Shaft)
- S-Type Reducer

Right Angle Shaft (Performance Table/Dimension)

- Gearmotor with Brake
- Water-resistant, Outdoor Gearmotor with Brake
- Gearmotor with Clutch /Brake
- Reduce (Double Shaft)
- S-Type Reducer

Hollow Shaft Solid Shaft Performance Table/Dimension

- Gearmotor with Brake
- Water-Resistant, Outdoor Gearmotor with Brake
- Reduce (Double Shaft)
- S-Type Reducer

Concentric Hollow Shaft Concentric Solid Shaft Performance Table/ Dimension

- Gearmotor with Brake
- Water-Resistant, Outdoor Gearmotor with Brake
- Reducer (Parallel Shaft)
- S-Type Reducer

Technical Information

- Standard Motors
- Cautions for Safety
- Option
- GT-STEP Index Gearmotor
- KOMPASS Gearbox